

- CONTACTS INCLUDED IN ASSEMBLY.
- MATL: STEEL, PER ASTM-A-109.
- FINISH: CADMIUM PER QQ-P-416.
- CONTACT BODY MATL: BERYLLIUM COPPER PER ASTM-B-197. BODY FINISH: PLATED GOLD, .000050 MIN THK PER MIL-G-45204 OVER NICKEL, .000050 MIN THK PER QQ-N-290. HOOD MATL: STAINLESS STEEL PER ASTM-A-167. HOOD FINISH: PASSIVATED PER ASTM-A-380.
- FINISH: PLATED ZINC .00020 MIN THK PER ASTM-B-633. YELLOW CHROMATE FINISH.
- MATL: BRASS PER ASTM-B-36.
- FINISH: PLATED GOLD, .000050 MIN THK PER MIL-G-45204 OVER COPPER, .000100 MIN THK PER MIL-C-14550.
- CONTACT BODY MATL: BERYLLIUM COPPER PER ASTM-B-197. BODY AND HOOD FINISH: PLATED GOLD, .000050 MIN THK PER MIL-G-45204 OVER COPPER, .000100 MIN THK PER MIL-C-14550. HOOD MATL: BRASS PER ASTM-B-36.
- FINISH: PLATED ZINC PER ASTM-B-633 .000200 MIN THK WITH SUPPLEMENTARY CHROMATE (Cr3+).

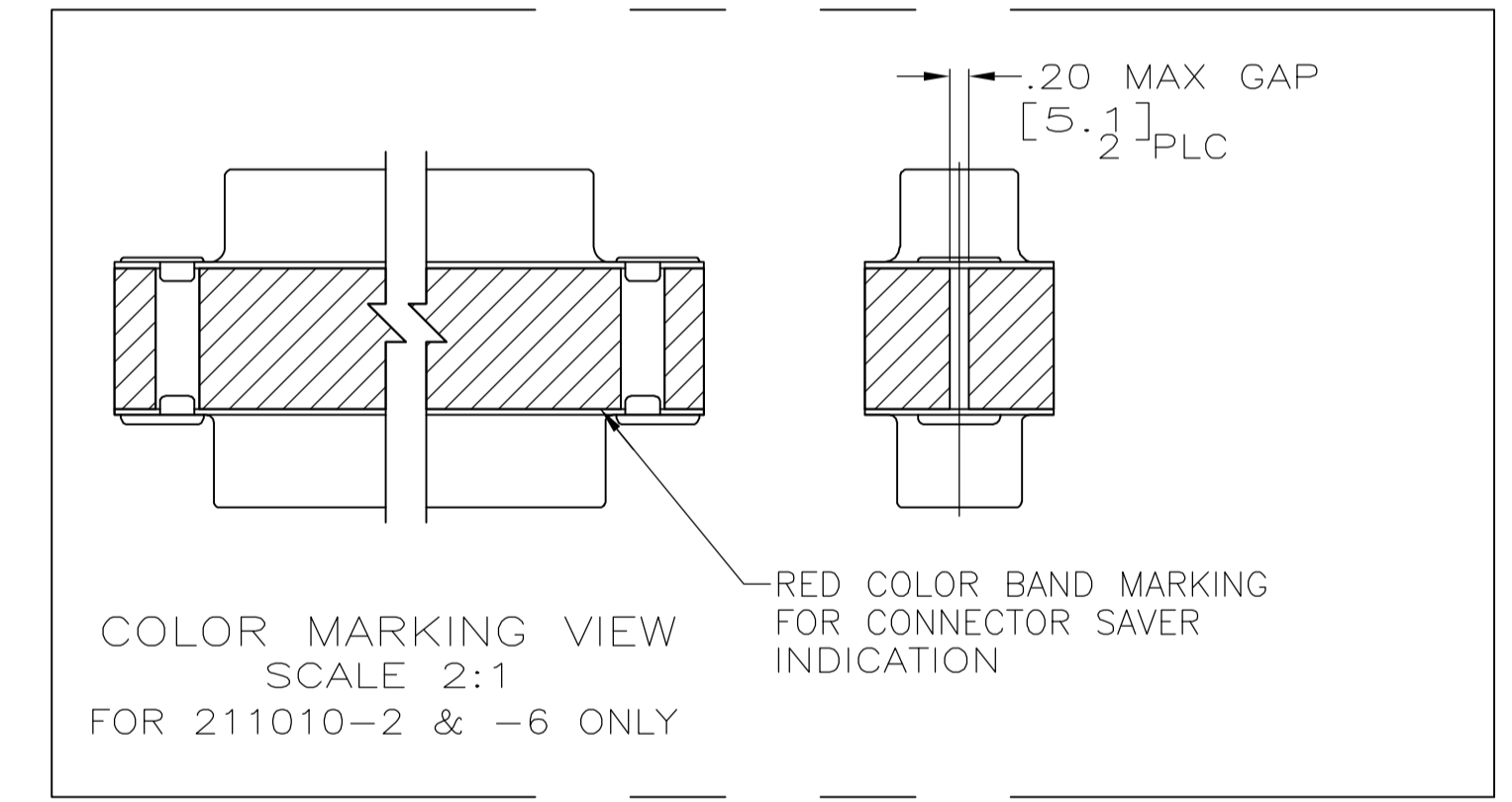

△△	△△	△	-	5-211010-1
△△	△△	△	R10002677-0106	211010-6
△△	△△	△	2A091-001W	211010-5
△△	△△	△	-	211010-4
△△	△△	△	(1J02-106)	211010-2
△△	△△	△	-	211010-1
EYELET	SHELLS	CONTACT	CUSTOMER P/N	PART NO.

THIS DRAWING IS A CONTROLLED DOCUMENT. DIMENSIONS: INCHES. TOLERANCES UNLESS OTHERWISE SPECIFIED: 0 PLC ± -, 1 PLC ± -, 2 PLC ± -, 3 PLC ± .005(0.13), 4 PLC ± -, ANGLES ± -.

APPROVED: T. THOMPSON, J. NORTON. Tyco Electronics Corporation, Harrisburg, PA 17105-3608. PRODUCT SPEC: CONNECTOR SAVER, AMPLIMITE 15 POSITION, SIZE 1, SERIES 90. APPLICATION SPEC: -.

MATERIAL: SEE CALLOUTS. FINISH: SEE CALLOUTS. WEIGHT: -. SIZE: A1. CAGE CODE: 00779. DRAWING NO: 211010. RESTRICTED TO: -.

CUSTOMER DRAWING. SCALE: 4:1. SHEET: 1 OF 1. REV: Y.